

積み木を作る問題

左の積み木を作るために、右から使う積み木を選びます。

使う積み木に○、使わない積み木に×をつけて答えましょう。

| | | | |
|---|-----|-----|-----|
| 1 | () | () | () |
| | | | |

| | | | |
|---|-----|-----|-----|
| 2 | () | () | () |
| | | | |

| | | | |
|---|-----|-----|-----|
| 3 | () | () | () |
| | | | |

積み木を作る問題

左の積み木を作るために、右から使う積み木を選びます。

使う積み木に○、使わない積み木に×をつけて答えましょう。

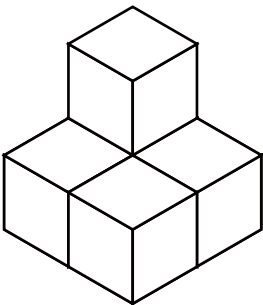
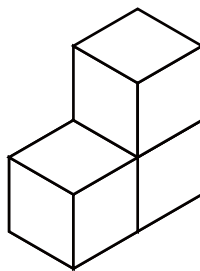
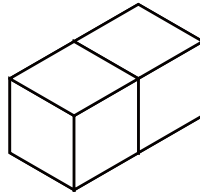
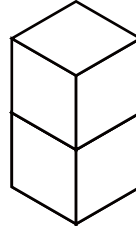
| | | | |
|---|---|--|---|
| 1 | () | () | () |
|  |  |  |  |

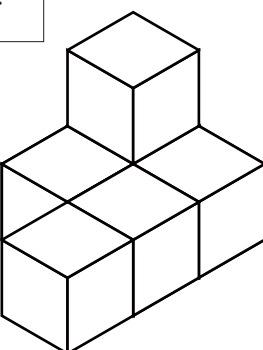
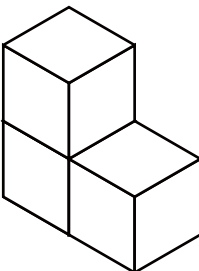
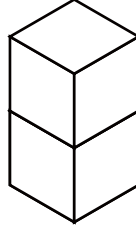
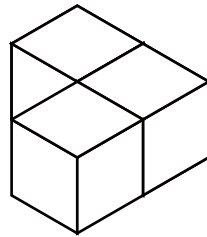
| | | | |
|---|---|--|---|
| 2 | () | () | () |
|  |  |  |  |

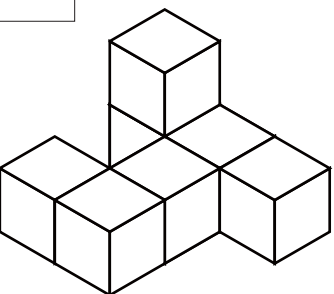
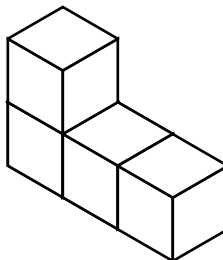
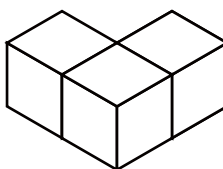
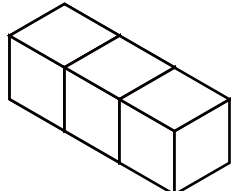
| | | | |
|---|---|--|---|
| 3 | () | () | () |
|  |  |  |  |

積み木を作る問題

左の積み木を作るために、右から使う積み木を選びます。

使う積み木に○、使わない積み木に×をつけて答えましょう。

| | | | |
|---|-----|-----|-----|
| 1 | () | () | () |
| | | | |

| | | | |
|---|-----|-----|-----|
| 2 | () | () | () |
| | | | |

| | | | |
|---|-----|-----|-----|
| 3 | () | () | () |
| | | | |

積み木を作る問題

左の積み木を作るために、右から使う積み木を選びます。

使う積み木に○、使わない積み木に×をつけて答えましょう。

| | | | |
|---|-----|-----|-----|
| 1 | () | () | () |
| | | | |

| | | | |
|---|-----|-----|-----|
| 2 | () | () | () |
| | | | |

| | | | |
|---|-----|-----|-----|
| 3 | () | () | () |
| | | | |